

Telco BMS

Telecom Battery Management System

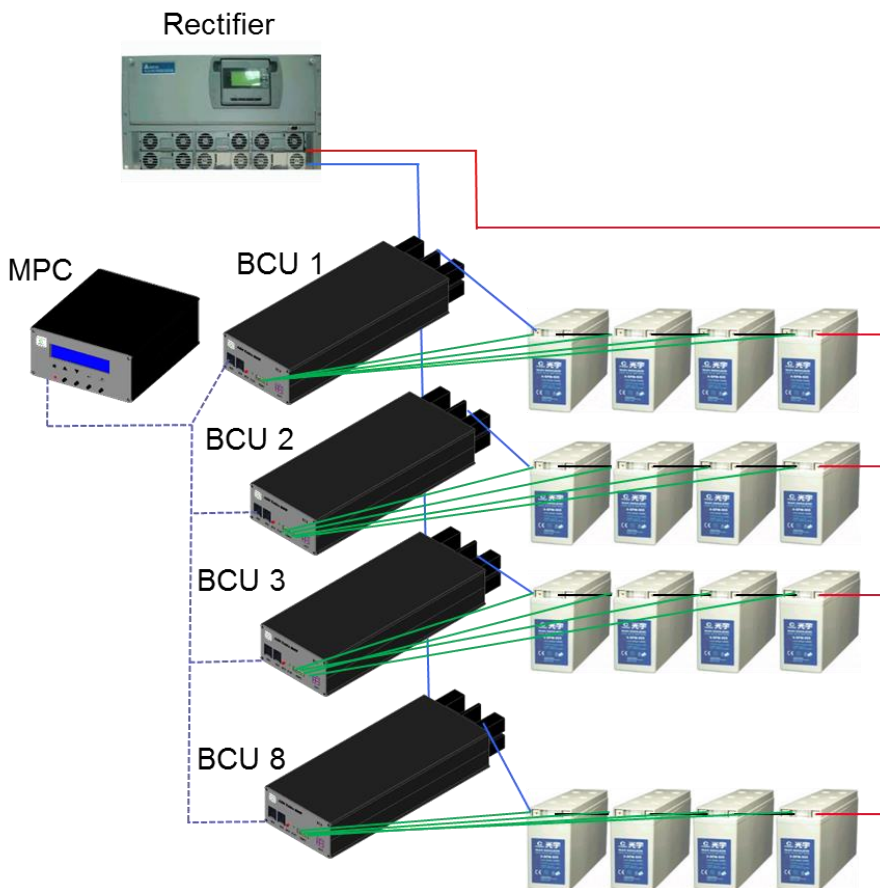

Existing battery operating conditions in Telco Sites

Telco rectifier systems are designed for “one group” batteries in the present GSM base stations. These systems can measure and limit only one group battery current because they have only one “battery” connection.

Existing rectifier design, 24 units of serially connected 2V / 400Ah VRLA cells are needed to be used. But 24 pcs, 2V/400Ah batteries need large footprint. Due to the volumetric limitations, instead of 24 pcs 2V battery, 4 units of 12V VRLA batteries serially connected and make 48V battery groups and these 3 or 5 groups (12 or 20 units of batteries are used) are parallel connected by that way the required energy capacity can be obtained.

Rectifier can charge the battery groups by limiting the battery group’s current in Constant Current “CC” and Constant Voltage “CV” (float) modes.

Either 3-5 groups or 1 group of battery connected to rectifier, rectifier doesn’t aware anything about each 12V batteries voltage levels and temperature conditions. Because, it is designed to control only one group of battery.

In present condition; there is no Battery Management System (BMS) at site applications.

Although it is expected that each parallel connected battery groups can take same amount of current during charge, due to the

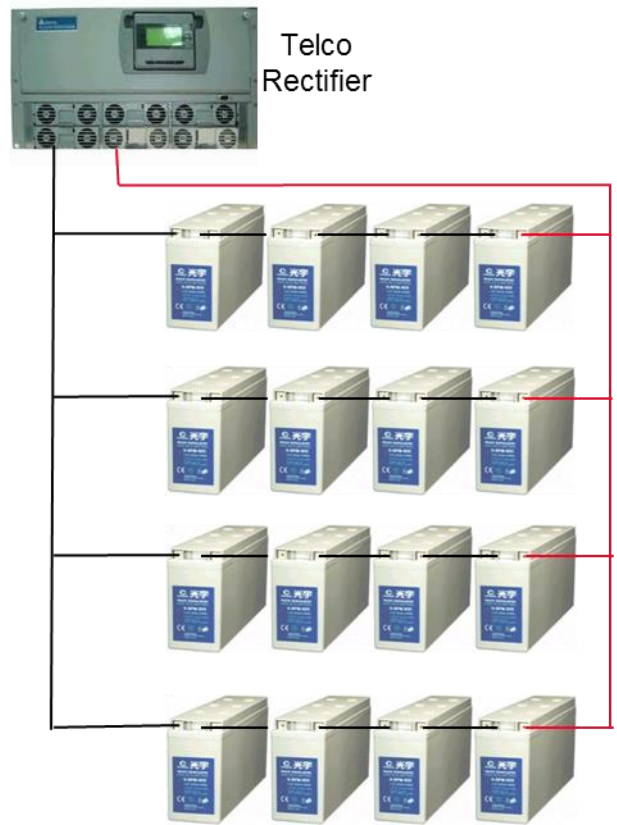

production differences and also the aging reasons battery groups do not take same amount of current in practice.

When the cycle counts increase, batteries cannot be charged properly due to the internal resistance differences. During the discharge mode these unbalanced situation can age the battery groups and the expected capacity of 400Ah cannot be obtained from the batteries.

Because of the wired parallel structure, any faulty battery can affect the battery group and also the total energy back up system.

Because of the wired parallel structure, any faulty battery can affect the battery group and also the total energy back up system.

Because of the wired parallel structure, any faulty battery can affect the battery group and also the total energy back up system.

Due to the asymmetric aging, capacity differences cause overcharge and rectifier cannot prevent overcharge of every single 12V batteries.

Due to the capacity differences, batteries are charged with higher voltage ranges from the recommended charging voltage of the VRLA battery manufacturer and rectifiers cannot prevent these overcharge situation.

Because of the Ah capacity and the internal resistance differences, battery groups cannot be charged equally. From the Ohm law; the current can be distributed the battery groups by the inverse proportion with the internal resistance. As a result, different internal resistance VRLA batteries can make unbalancing on group current. This makes higher charging current to some group.

For instance when the current limitation of the rectifier is set to 40A, related with the internal resistance during the end of charge each 3 groups of VRLA batteries can take 2A and the remaining 4th group of the battery can take 34A. This means 4th group VRLA batteries are charged with 3.5 times more current of the manufacturer's recommended charging current. This cause faster aging the batteries.



Telco Rectifier

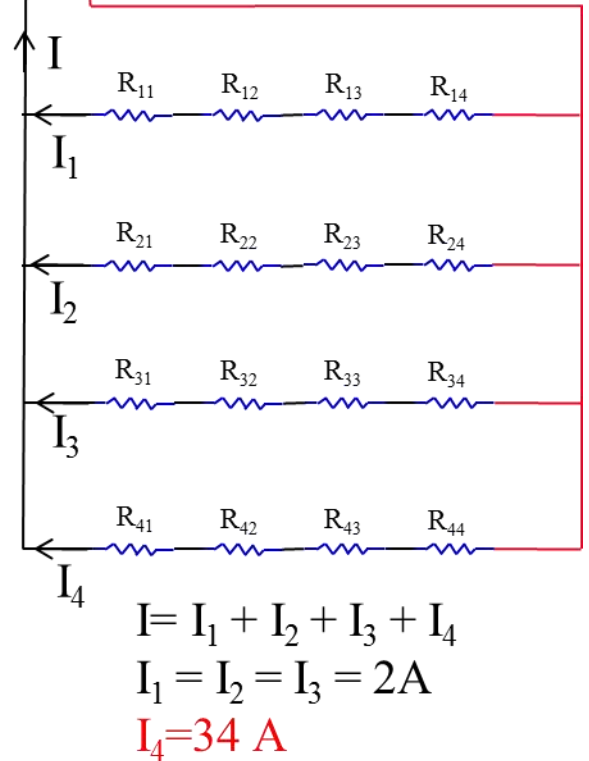

Because of that reason, GSM operators do not prefer to combine old and new battery groups in the same energy back-up unit. Although a few units of VRLA batteries are corrupted, GSM operators replace all 20 or 12 units of batteries with the new ones because they cannot mix them.

For example, due its aging and manufacturing conditions R23 internal resistance VRLA battery could behave different from the other batteries inside the group.

Inside the same group R22 battery's internal resistance might get lower and the R23 one has got high internal resistance with this example combination. Because 4 batteries inside the group should take the current equally, one battery could be overcharged and its voltage could reach >14V. The other low internal resistance battery has got lower voltage but the total group voltage remain same.

From this situation R23 can be overcharged and release H2 and O2 gases to outside which results electrolyte losses. Rectifier doesn't aware anything about this situation. When a battery loses its electrolyte, its internal resistance increases. Continuous cycling in this condition, corrupts and ages that battery and decreases its capacity. This causes asymmetric aging of some batteries in the VRLA battery group.

GSM operator cannot be informed about the operating conditions of the VRLA battery groups. Operators detect the problem when the back-up time decreases. They send their maintenance team to the sites.

For detecting the faulty VRLA battery, 24 hours long capacity test needed to be done to each battery. But the operator maintenance teams do not have that much time during operation at remote site. Maintenance team replace all existing 16-20 batteries with the new ones and replaced ones labeled as "trash".

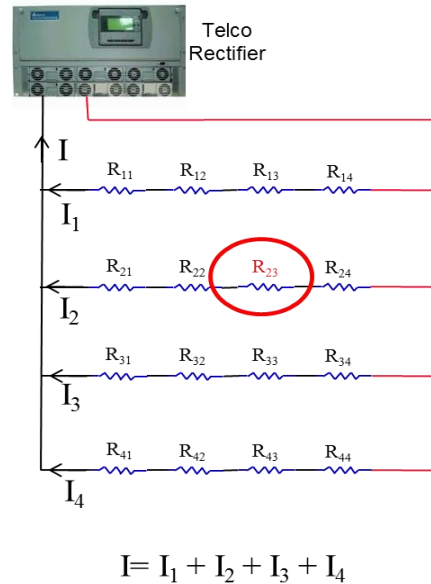

All replaced VRLA batteries send to GSM operator's regional warehouses. If it is possible to make capacity test in warehouse, they make these tests to replaced VRLA batteries and detect the real corrupted batteries. In some of the warehouse they don't have that kind of test equipment and they directly to send the all batteries to trash.

Due to the different aging parameters and site conditions; after 2 years operation time of VRLA batteries, they considerably lose their Ah energy storage capacity.

Site maintenance team cannot easily detect the lower capacity VRLA batteries. They cannot detect 2 or 3 corrupted VRLA battery in all 16-20 batteries. As a result they need to replace all batteries in the site. These batteries are almost 600kg weight which brings great amount of transportation costs and great amount of labor cost for testing. All these procedures will bring a significant amount of Operation Expenses (OPEX) to GSM operators.

Telco BMS uses the rectifier supplied current and voltage levels and take care of up to 16 units of 48V VRLA Battery groups. During the charge process, each battery voltage levels and group temperatures are monitored by the system. Battery Control Unit (BCU) modules make current limitations, voltage and temperature monitoring and communicate through by using Mod-Bus like ASCII protocol to Main Process Controller (MPC) module. MPC controls the all system and takes current limitation decisions and charge cut off decisions. At the same time MPC communicate with PC over USB 2.0 or Ethernet ports, with site monitoring system over RS485 port and internal GSM/GPRS modem daughterboard by separate serial interfaces. Each battery group is controlled by one BCU modules. Current and voltage control in BCU modules; prevent overcharge during charge process caused by the VRLA battery aging and asymmetric capacity.

When a VRLA battery voltage exceeds V_{max} (default 14V) inside the group, even if group voltage does not reach the V_{float} level, BCU decreases the current limitation value and it doesn't permit any battery to exceed 14V in the group.

If monitored VRLA battery's temperature exceeds the limited operation temperature levels, BCU directly decrease the current and if the temperature doesn't cool down, it could able to cut down the charge mode.

Telco BMS can "balance" 12V battery voltage in the groups. ABC (Active Balancing Circuit) hardware in BCU can inject 1-2A balancing charge current to selected 12V battery. When the active balancing applied onto lower voltage batteries after the charge, all battery voltages in the group can be balanced for a while. This method fixes battery «top» voltages to preferred voltage level and cycling can be done from this point with the help of overdischarge control at the bottom.

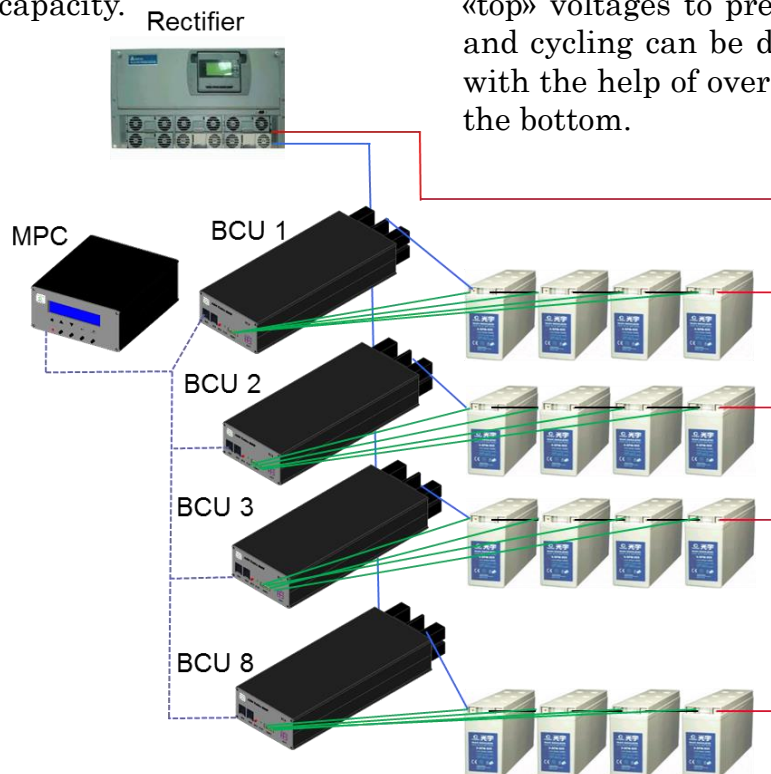

In “discharge mode” there is no current limitation applied. However with the one advantage of Telco BMS , during discharge mode higher voltage VRLA battery group cannot charge the lower voltage VRLA battery groups. Only current flow to load is permitted.

In discharge; if any battery’s voltage drops to V_{min} (default 10,8V which means 1,8V/cell- but it can be edited) system directly stop discharge from that group and the remaining groups carry the site. With this advantage overdischarge and sulphation of VRLA batteries can be prevented.

On MPC, LCD display and 4 button menu system is used for Human Machine Interface (HMI). With the remote monitoring; operation engineer in GSM operator OMC (Operation and Maintenance Center) can monitor and control the system parameters without sending any site maintenance technician to any site.



Each cycle; over temperature and low capacity VRLA Battery which bellows 80% DoD pointed by Telco BMS LCD menu.

If a group of VRLA batteries are needed to be replaced, maintenance technician can define from LCD menu.

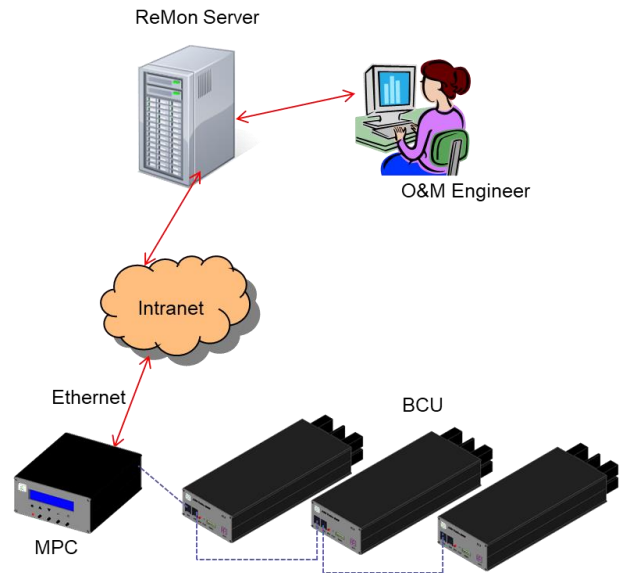

When the GSM operator’s maintenance team comes to site they can see the problematic batteries on LCD menu and they can only replace those batteries. Also for confirmation by using remote monitoring and controlling system the maintenance team can ask to operation engineer in OMC to decide whether to replace that battery or not. On the other hand, the site engineer in the maintenance team can connect his computer to USB port of MPC and monitor and control the Telco BMS directly from his computer too.

If the battery groups voltage / temperature cable are mis-connected, Telco BMS can understand this situation and shows the fault in which group by that way system warn the maintenance team .

12V VRLA Battery Active Balancing

Because of slightly different production parameters and conditions, storage and operation conditions 12V VRLA batteries in serial group can have non equal Ah capacities. This difference can increase after a hundreds of cycles. That imbalance can force lower capacity ones to overcharge condition because they will be fully charged before other higher capacity batteries. Because group voltage did not reach to float voltage, charger does not limit the current but lower capacity 12V battery can exceed overcharge voltage level. Releasing O₂ and H₂ gases in overcharge “dry” the battery. This situation ages this battery and pushes it lower Ah capacity. That unbalancing event kills battery after a couple of ten cycles later.

Telco-BMS has “Active Balancing Circuit” in BCU modules to prevent overcharge of 12V batteries and “balance” them one by one. In case of any 12V battery reaches to overcharge voltage limit during charge, BCU “cuts” the charging current. MPC orders to active balancing mode to BCU.

BCU active balancing circuit has “Flying Capacitor» type Active Balancing circuit. Low ESR type capacitors periodically switches between two neighbour batteries. Capacitor charges from higher voltage one and discharges onto lower voltage one. MPC collects all voltage information from BCU modules and decides batteries should be “balanced”.

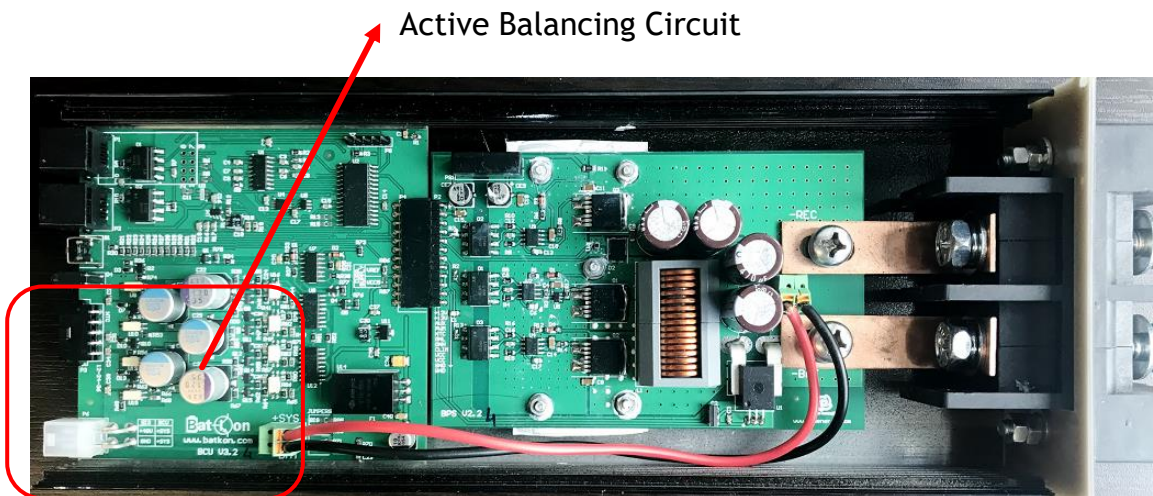

Battery Control Unit - BCU

Aged and New VRLA Batteries mixed usage

By using Telco BMS, faulty VRLA battery can be easily pointed and replaced. The new batteries can be used mixed with aged batteries. With this situation over current and voltage problems (14V charging voltage limit) can be eliminated by the Telco BMS system control algorithm. Telco Rectifier systems cannot perform this operation because they cannot measure each 12V battery voltage.

When a faulty VRLA battery replaced with a new battery in the aged battery group, it could help the battery group to give energy to load until remaining aged batteries reach their end of usage life. In that case the new battery could not be properly charged but if it can be charged long time it can reach its 100% Ah capacity. Later each discharge new battery can be discharged with the same DoD of older ones. That means new battery has better DoD condition. This application as replacing all battery can increase the OPEX and also means sending 3 units of usable batteries to trash. By making mixed usage old and new batteries together can have lower operation cost.

In the example given above, the new battery and aged batteries all charged with 10A charging current. Because the 4th battery's capacity is lower than the other, it can be fully charged earlier than the others and it could reach the float charging limit 13,38V while the others do not reach that voltage level..

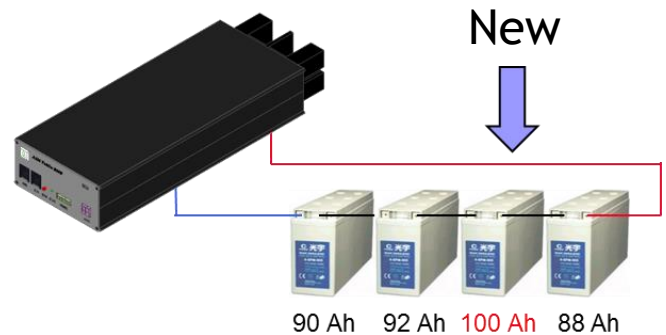

In normal operation rectifier just controls float charging voltage 53,5V and 10A limiting charge current. As a result that aged 4th battery voltage can exceed 14V and it can be overcharged. Until total voltage reach 53,5V the charging current does not get lower. In the operation exceeding 14V, overcharged battery start to release gas (H_2 and O_2) and loose its electrolyte. This type of usage ages the battery faster. If the charging operation is controlled and current lowered, overcharging can be prevented. Telco BMS does that.

With this method only faulty battery or batteries who has capacity level lower than 80% can be replaced. However according to the GSM operators strategic decision for instance if one battery's capacity drops below 80% and the remaining capacities are 85%. Because adding a new battery into the very aged batteries cannot be solution in midterm. Instead of this, all group replacing can be sometimes better solution. This decision can be guided by Telco BMS by the given algorithm which is decided by the GSM operator's maintenance engineers.

Temperature Compensation

VRLA batteries temperature compensation values are recommended by the manufacturers and these temperature compensation values differs manufacturer by manufacturer

Rectifiers have got only 1 or 2 temperature sensors and generally both of them are placed inside one battery group.

For example; $V_{floatCell} = 2.23 + (25 - t) * 0.003$ formula gives that when 30 °C operation temperature float voltage should be set to 53,16V

Sometimes GSM site maintenance technician doesn't know deeply how to use the control menu of the rectifier. In order not to set wrong values they keep the temperature compensation values at default parameters. Mostly this value does not match with installed VRLA battery manufacturer's parameters.

On the other hand in 4 shelf rack cabinet, the top floor and the bottom floor have got different temperature ranges due to the thermal convection. Because of that reason each group should have separated temperature compensation.



Each group voltage in Telco BMS is measured separately and temperature compensation is made according to these values. With this method; wrong parameter setting which results lower or over charging voltage can be prevented. By using Telco BMS if the top floor groups temperature is almost 30°C and the bottom group is almost 25°C each group is charged proper charging voltage. By proper charging, thermal aging can be decreased.



Lithium Ion and VRLA Battery Hybrid Operation

One or more group of Lithium-Ion Battery (Lithium Iron Phosphate-LFP, Lithium Manganese Oxide-LMO, Lithium Cobalt Oxide-LCO, Lithium Nickel-Cobalt Oxide-NCA etc.) can also be connected to Telco BMS ports.

If one group is Lithium and the remaining groups are VRLA batteries, Lithium can be charged with 25A current quickly. If faster charging required 2 BCU modules of Telco BMS can be parallel charge Lithium with upto 50 A.

During the electricity cut off, firstly Lithium Battery is discharged. When the lithium battery is fully discharged, VRLA groups started to be discharged. This control algorithm controlled by Telco BMS's MPC Module.

With this hybrid operation, when the electricity cut off bellow approximately 2 hours, VRLA batteries don't be cycled and the VRLA batteries operation life will get increased.

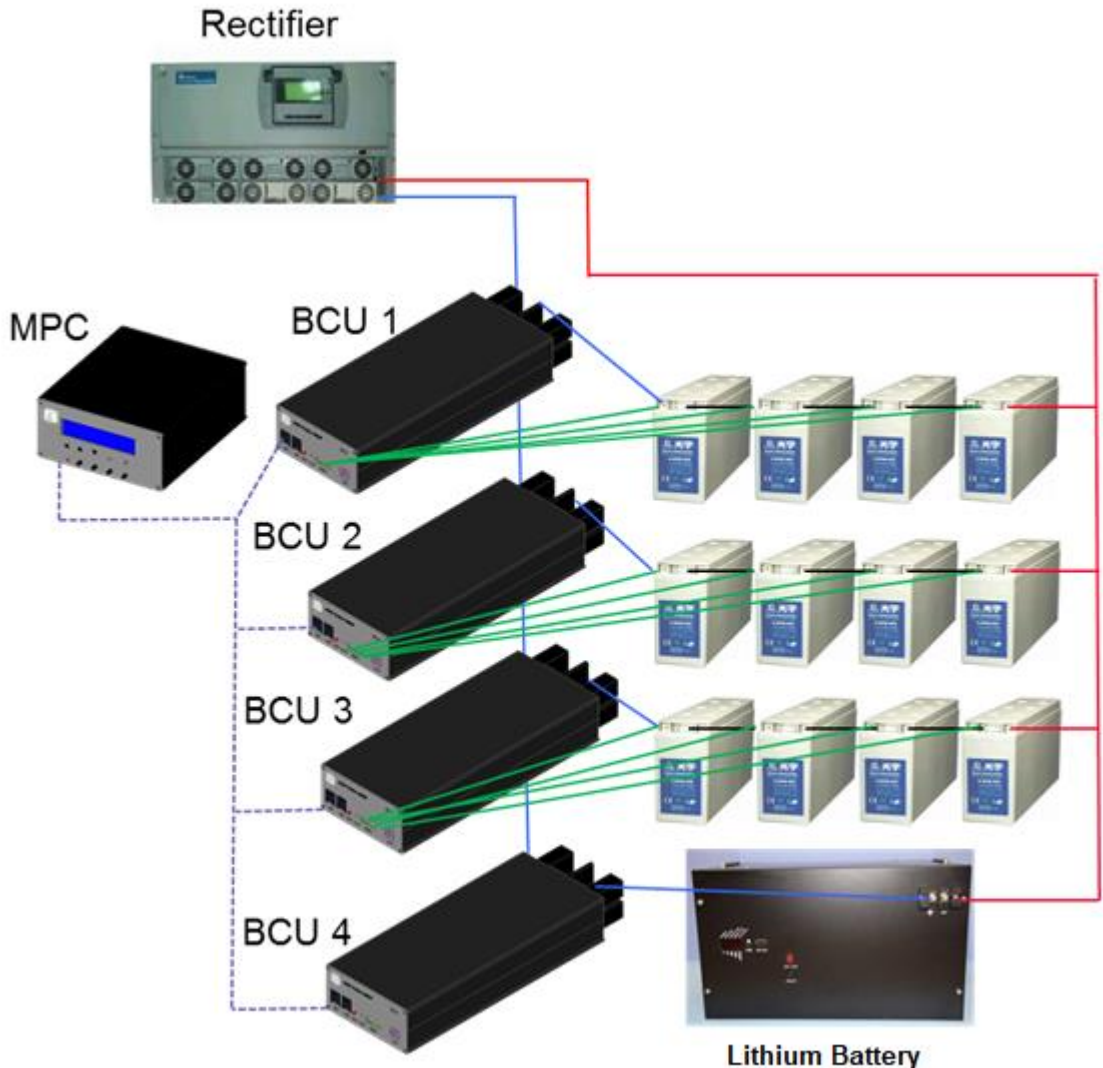

Telco BMS Mechanical Structure

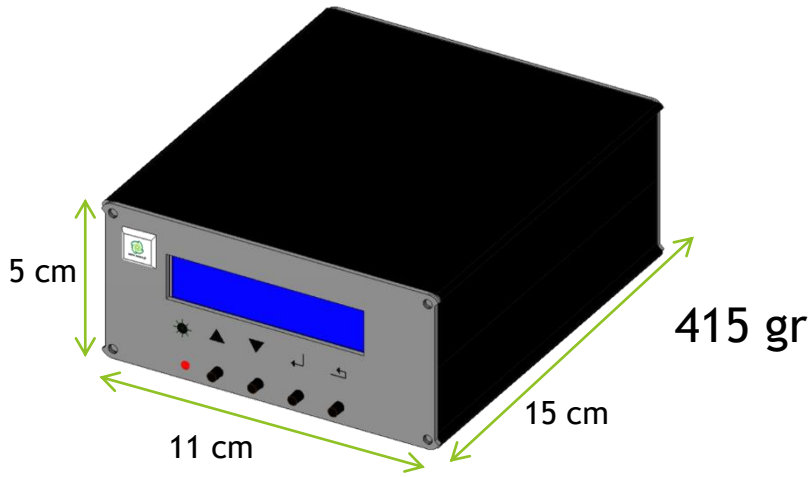

MPC

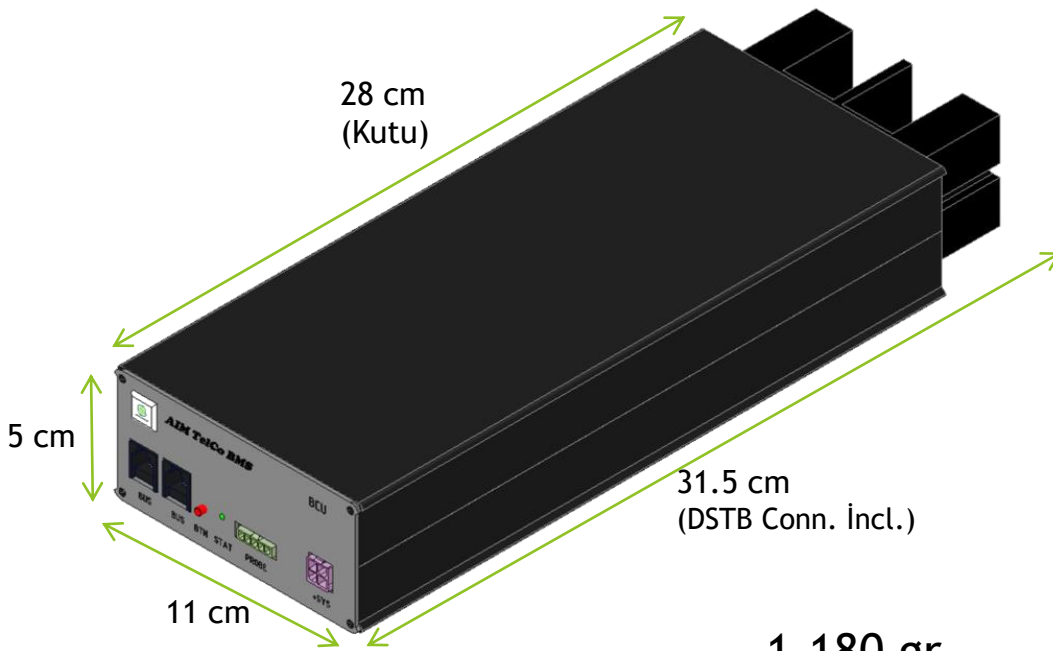

BCU

Why Telco BMS is needed ?

- Telco Battery Management System significantly increase the operation lifetime of VRLA batteries.
- Telco BMS can lower unnecessary VRLA battery scrap rates
- By the remote maintenance feature of Telco BMS ; power backup infrastructure of base station sites can be monitored and controlled from the OMC of GSM Operator. The potential faults of the battery backup systems can early be detected.
- Wrong parameter setting to rectifier or default parameter operating can be prevented.
- Lithium and VRLA battery can hybrid operated. Short energy cut-off will not decrease VRLA cycle life.
- In overall; GSM Operator's "Operational Expenses" will get lower.

Technical Parameters:

Physical Dimensions:

- MPC: 5 x 11 x 15 cm (Height x Width x Depth) , 450 gr
- BCU: 5 x 11 x 30.5 cm (Height x Width x Depth) , 1250 gr

Electrical:

- Input Voltage: -42...-56V DC
- Output Voltage: -42...-55V DC
- Charge Current: 0 ... 25 A (per BCU)
- Discharge Current: 0 ... 60 A (per BCU)

Environmental:

- Operation Temperature: 0 .. 50 °C
- Relative Humidity: 90% RH

Interfaces:

- USB-A 2.0 computer/memory interface
- RJ45 10/100 Mbps Ethernet interface
- Two pin RS485 interface
- Internal GSM/GPRS modem daughterboard
- Remote Management Server connection
- System programming via 2 x 16 ch. LCD and 4 button navigation
- Dry contact alarm relay interface (NO or NC)
- 5 wire probe interfaces for 12V battery voltage and temperature measurement

Standards:

- EN-61204-3 : EMC requirements for switch mode power supply (SMPS)
- EN-62368-1 :Part-1 Safety requirements Audio/video, information and communication technology equipment
- CE : 2020 PTC-1366